

AWK-5222 Series

Industrial IEEE 802.11a/b/g dual-RF wireless AP/bridge/client



- > IEEE 802.11a/b/g compliant
- > Dual-RF design: 2.4 GHz and/or 5 GHz RF bands
- > Supports 100 ms redundant roaming
- > Compliant with essential sections of EN 50155
- > -40 to 75°C operating temperature range (T models)

Introduction

Moxa's wireless redundancy technology allows you to set up independent wireless connections to avoid interruptions in transmission, even if interference occurs on one of the supported frequencies. The AWK-5222 is equipped with the newest proprietary wireless redundancy technology, which has two independent RF modules, and supports a greater variety of wireless configurations and applications. The redundant wireless connections increase the reliability of the entire wireless network. The AWK-5222 is compliant with the essential sections of EN 50155, covering operating temperature, power input voltage, surge, ESD and vibration. The AWK-5222 is rugged enough to help you establish the most robust wireless connection for critical industrial wireless applications.

Redundancy to Increase System Reliability

- Dual DC power inputs and PoE
- Dual RF design with 2.4 and/or 5 GHz dual-band operation for redundant WLAN connections
- Redundant roaming for fast and stable handoff
- Ethernet redundancy via RSTP

Specifications for Industrial-grade Applications

- Industrial-grade QoS and VLAN for efficient data traffic management
- Long-distance wireless transmission over 10 km
- Integrated DI/DO for on-site monitoring and warnings
- Signal strength LEDs for easy deployment and antenna alignment

Specifications

WLAN Interface

Standards:

IEEE 802.11a/b/g for Wireless LAN
 IEEE 802.11i for Wireless Security
 IEEE 802.3 for 10BaseT(X)
 IEEE 802.3u for 100BaseT(X)
 IEEE 802.3af for Power-over-Ethernet
 IEEE 802.1D for Spanning Tree Protocol
 IEEE 802.1w for Rapid STP
 IEEE 802.1Q for VLAN

Spread Spectrum and Modulation (typical):

- DSSS with DBPSK, DQPSK, CCK
- OFDM with BPSK, QPSK, 16QAM, 64QAM
 64QAM @ 54 Mbps, 16QAM @ 24/36 Mbps, QPSK @ 12/18 Mbps,
 CCK @ 11/5.5 Mbps, DQPSK @ 2 Mbps, DBSK @ 1 Mbps
- 802.11b: CCK @ 11/5.5 Mbps, DQPSK @ 2 Mbps,
 DBPSK @ 11 Mbps
- 802.11a/g: 64QAM @ 54/48 Mbps, 16QAM @ 36/24 Mbps,
 QPSK @ 18/12 Mbps, BPSK @ 9/6 Mbps

Operating Channels (central frequency):

US:

2.412 to 2.462 GHz (11 channels)
 5.18 to 5.24 GHz (4 channels)

EU:

2.412 to 2.472 GHz (13 channels)
 5.18 to 5.24 GHz (4 channels)

JP:

2.412 to 2.472 GHz (13 channels, OFDM)
 2.412 to 2.484 GHz (14 channels, DSSS)
 5.18 to 5.24 GHz (4 channels for W52)

Security:

- SSID broadcast enable/disable
- Firewall for MAC/IP/Protocol/Port-based filtering
- 64-bit and 128-bit WEP encryption, WPA /WPA2 Personal and Enterprise (IEEE 802.1X/RADIUS, TKIP and AES)

Transmission Rates:

802.11b: 1, 2, 5.5, 11 Mbps
 802.11a/g: 6, 9, 12, 18, 24, 36, 48, 54 Mbps

TX Transmit Power:

802.11b:
 Typ. 23±1.5 dBm @ 1 to 11 Mbps
 802.11g:
 Typ. 20±1.5 dBm @ 6 to 24 Mbps, Typ. 19±1.5 dBm @ 36 Mbps, Typ.
 18±1.5 dBm @ 48 Mbps, Typ. 17±1.5 dBm @ 54 Mbps
 802.11a:
 Typ. 18±1.5 dBm @ 6 to 24 Mbps, Typ. 16±1.5 dBm @ 36 to 48 Mbps,
 Typ. 15±1.5 dBm @ 54 Mbps

RX Sensitivity:

802.11b:
 -97 dBm @ 1 Mbps, -94 dBm @ 2 Mbps, -92 dBm @ 5.5 Mbps, -90
 dBm @ 11 Mbps
 802.11g:
 -93 dBm @ 6 Mbps, -91 dBm @ 9 Mbps, -90 dBm @ 12 Mbps, -88
 dBm @ 18 Mbps, -84 dBm @ 24 Mbps, -80 dBm @ 36 Mbps, -76 dBm
 @ 48 Mbps, -74 dBm @ 54 Mbps
 802.11a:
 -90 dBm @ 6 Mbps, -89 dBm @ 9 Mbps, -89 dBm @ 12 Mbps, -85
 dBm @ 18 Mbps, -83 dBm @ 24 Mbps, -79 dBm @ 36 Mbps, -75 dBm
 @ 48 Mbps, -74 dBm @ 54 Mbps

Protocol Support

General Protocols: Proxy ARP, DNS, HTTP, HTTPS, IP, ICMP, SNMP, TCP, UDP, RADIUS, SNMP, PPPoE, DHCP

AP-only Protocols: ARP, BOOTP, DHCP, STP/RSTP (IEEE 802.1D/w)

Interface

Default Antennas*:

2 dual-band omni-directional antennas, 2 dBi, RP-SMA (male)

*Only available with the AWK-5222 model

Connector for External Antennas:

AWK-5222: RP-SMA (female)

AWK-5222-M12: QMA (female)

RJ45 Ports: 2, 10/100BaseT(X), auto negotiation speed, F/H duplex mode, and auto MDI/MDI-X connection (AWK-5222 only)

M12 Ports: 2, 10/100BaseT(X) auto negotiation speed, F/H duplex mode, and auto MDI/MDI-X connection (AWK-5222-M12 only)

Console Port: RS-232 (RJ45-type)

LED Indicators: PWR1, PWR2, PoE, FAULT, STATE, WLAN1, WLAN2, 10M, 100M (TP port), LAN1, LAN2 (M12 port)

Alarm Contact (digital output): 1 relay output with current carrying capacity of 1 A @ 24 VDC

Digital Inputs: 2 electrically isolated inputs

• +13 to +30 V for state "1"

• +3 to -30 V for state "0"

• Max. input current: 8 mA

Physical Characteristics

Housing: Metal, IP30 protection

Weight: 1.1 kg

Dimensions: 62 x 135 x 105 mm (2.44 x 5.31 x 4.13 in)

Installation: DIN-Rail mounting (standard), Wall mounting (optional)

Environmental Limits

Operating Temperature:

Standard Models: -25 to 60°C (-13 to 140°F)

Wide Temp. Models: -40 to 75°C (-40 to 167°F)

Storage Temperature: -40 to 85°C (-40 to 185°F)

Ambient Relative Humidity: 5% to 95% (non-condensing)

Power Requirements

Input Voltage: 12 to 48 VDC, redundant dual DC power inputs or 48 VDC Power-over-Ethernet (IEEE 802.3af compliant)

*Compliant with EN 50155 on 24 VDC

Connector: 10-pin removable terminal block

Power Consumption: 12 to 48 VDC, 800 mA (max.)

Reverse Polarity Protection: Present

Standards and Certifications

Safety: UL 60950-1, EN 60950-1

EMC: EN 301 489-1/17, FCC Part 15 Subpart B, EN 55022/55024, IEC 61000-6-2/4

Radio: EN 300 328, EN 301 893

Rail Traffic: EN 50155, EN 50121-1/4

Note: Please check Moxa's website for the most up-to-date certification status.

Reliability

MTBF (mean time between failures):

AWK-5222: 291,367 hrs

Warranty

Warranty Period: 5 years

Details: See www.moxa.com/warranty

Dimensions

AWK-5222

AWK-5222-M12

Unit: mm (inch)

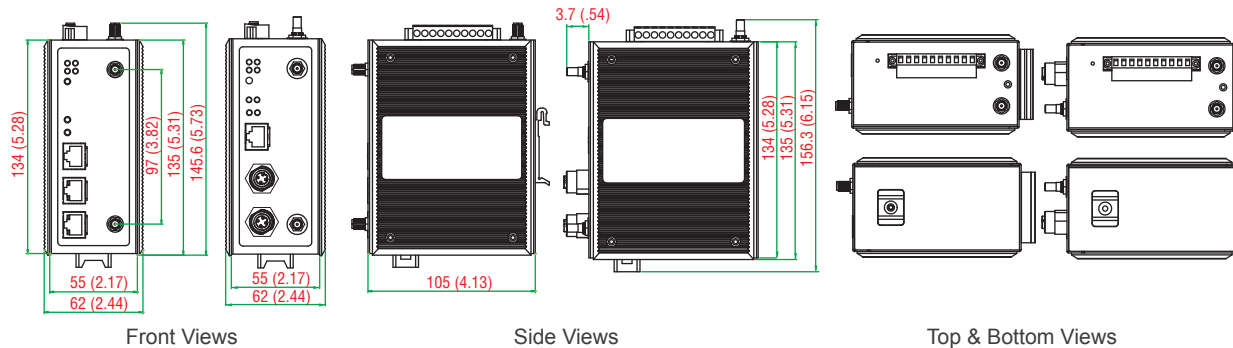

Ordering Information

Model Name	Available Models		Port Interface		Antenna Interface	
	Standard Temperature (-25 to 60°C)	Wide Temperature (-40 to 75°C)	2, 10/100BaseT(X)		RP-SMA	QMA
			RJ45	M12		
AWK-5222						
AWK-5222-US	✓	-	✓	-	✓	-
AWK-5222-EU	✓	-	✓	-	✓	-
AWK-5222-US-T	-	✓	✓	-	✓	-
AWK-5222-EU-T	-	✓	✓	-	✓	-
AWK-5222-M12						
AWK-5222-M12-US	✓	-	-	✓	-	✓
AWK-5222-M12-EU	✓	-	-	✓	-	✓
AWK-5222-M12-JP	✓	-	-	✓	-	✓
AWK-5222-M12-US-T	-	✓	-	✓	-	✓
AWK-5222-M12-EU-T	-	✓	-	✓	-	✓
AWK-5222-M12-JP-T	-	✓	-	✓	-	✓

Note:

US: USA band

EU: Europe band

JP: Japan band

Note: Please visit Moxa's website for a complete list of optional wireless accessories and antennas available for Moxa's wireless products.

Package Checklist

- AWK-5222 wireless AP/bridge/client
- Cable holder with one screw
- 2 plastic RJ45 protective caps for LAN & Console ports
- DIN-Rail kit
- Documentation and software CD
- Quick installation guide (printed)
- Warranty card

Note: 2 dual-band omni-directional antennas are included with the AWK-5222 model.

Wireless Antenna Selection Guide

IEEE 802.11b/g 2.4 GHz Wireless Antennas



	ANT-WSB-AHRM-05-1.5m	ANT-WSB-ANF-09	ANT-WSB-PNF-12	ANT-WSB-PNF-18	ANT-WSB5-ANF-12	ANT-WSB5-PNF-18
Frequency Range	2.4 to 2.5 GHz				5.1 to 5.9 GHz	
Antenna Type	$\lambda/4$ Dipole	Omni-directional	Directional, Panel	Directional, Panel	Omni-directional	Directional, Panel
Typical Antenna Gain	5 dBi	9 dBi	12 dBi	18 dBi	12 dBi	18 dBi
Description	2.4 GHz, omni-directional/dipole antenna, 5 dBi	2.4GHz, omni-directional antenna, 9 dBi, N-type (female)	2.4 GHz, panel antenna, 12 dBi, N-type (female)	2.4 GHz, panel antenna, 18 dBi, N-type (female)	5 GHz, omni-directional antenna, 12 dBi, N-type (female)	5 GHz, panel antenna, 18 dBi, N-type (female)
Impedance	50 \pm 5 ohms	50 \pm 5 ohms	50 \pm 5 ohms	50 \pm 5 ohms	50 \pm 5 ohms	50 \pm 5 ohms
Polarization	Vertical	Linear	Linear	Linear	Linear	Linear
HPBW/Horizontal	360°	360°	50°	30°	360°	10°
HPBW/Vertical	–	10°	30°	20°	6°	10°
V.S.W.R.	2.0	1 : 1.3 Max.	1 : 1.5 Max.	1 : 1.5 Max.	1 : 1.3 Max.	1 : 1.5 Max.
Power Handling	–	15 W Max.	10 W Max.	15 W Max.	10 W Max.	10 W Max.
Connector(s)	RP-SMA (male)	N-type (female)	N-type (female)	N-type (female)	N-type (female)	N-type (female)
Operating Temperature	-40 to 80°C	-40 to 80°C	-40 to 80°C	-40 to 80°C	-40 to 80°C	-40 to 80°C
IP rating	–	IP65	IP65	IP65	IP65	IP65
Antenna Profile	–	420 mm length	215 x 90 x 30 mm	270 x 205 x 15 mm	420 mm length	270 x 205 x 15 mm
Weight	300 g	430 g	560 g	310 g	430 g	990 g
Related Products	AWK-1121/1127, AWK-3121, AWK-3121-SSC, AWK-3131, AWK-5222, AWK-5232, NPort W2150/2250 Plus, NPort W2004	AWK-1121/1127, AWK-3121, AWK-3131, AWK-4121, AWK-4131, AWK-5222, AWK-5232, AWK-6222, AWK-6232, NPort W2150/2250 Plus, NPort W2004				

IEEE 802.11a/b/g 2.4/5 GHz Dual-band Antennas



	ANT-WDB-ANM-0502	ANT-WDB-ANM-0407	ANT-WDB-ANF-0407	ANT-WDB-ANM-0609	ANT-WDB-ANF-0609	ANT-WDB-PNF-1518
Frequency Range	2.4 to 2.5 / 5.1 to 5.9 GHz					
Antenna Type	Omni-directional	Omni-directional	Omni-directional	Omni-directional	Omni-directional	Directional, Panel
Typical Antenna Gain	2/5 dBi	4/7 dBi	4/7 dBi	6/9 dBi	6/9 dBi	15/18 dBi
Description	2.4/5 GHz, dual-band omni-directional antenna, 2/5 dBi, N-type (male)	2.4/5 GHz, dual-band omni-directional antenna, 4/7 dBi, N-type (male)	2.4/5 GHz, dual-band omni-directional antenna, 4/7 dBi, N-type (female)	2.4/5 GHz, dual-band omni-directional antenna, 6/9 dBi, N-type (male)	2.4/5 GHz, dual-band omni-directional antenna, 6/9 dBi, N-type (female)	2.4/5 GHz, dual-band panel antenna, 15/18 dBi, N-type (female)
Impedance	50 \pm 5 ohms	50 \pm 5 ohms	50 \pm 5 ohms	50 \pm 5 ohms	50 \pm 5 ohms	50 \pm 5 ohms
Polarization	Linear	Linear	Linear	Linear	Linear	Linear
HPBW/Horizontal	360°	360°	360°	360°	360°	50/10°
HPBW/Vertical	65°	10/8°	10/8°	10/8°	10/8°	30/10°
V.S.W.R.	1 : 2.0 Max.	1 : 1.5 Max.	1 : 1.5 Max.	1 : 1.5 Max.	1 : 1.5 Max.	1 : 1.5 Max.
Power Handling	2 W Max.	10 W Max.	10 W Max.	10 W Max.	10 W Max.	20 W Max.
Connector(s)	N-type (male)	N-type (male)	N-type (female)	N-type (male)	N-type (female)	N-type (female)
Operating Temperature	-40 to 80°C	-40 to 80°C	-40 to 80°C	-40 to 80°C	-40 to 80°C	-40 to 80°C
IP rating	IP67	IP65	IP65	IP65	IP65	IP65
Antenna Profile	220 mm length	220 mm length	260 mm length	632 mm length	660 mm length	270 x 205 x 15 mm
Weight	72 g	115g	155 g	238 g	286 g	1020 \pm 10 g
Related Products	AWK-4121, AWK-4131, AWK-6222, AWK-6232		AWK-1121/1127, AWK-3121, AWK-3131, AWK-4121, AWK-4131, AWK-5222, AWK-5232, AWK-6222, AWK-6232, NPort W2150/2250 Plus, NPort W2004	AWK-4121, AWK-4131, AWK-6222, AWK-6232	AWK-1121/1127, AWK-3121, AWK-3131, AWK-4121, AWK-4131, AWK-5222, AWK-5232, AWK-6222, AWK-6232, NPort W2150/2250 Plus, NPort W2004	

Wireless Accessories Selection Guide

Cables											
	CRF-N0117SA-3M	CRF-N0429N-3M	A-CRF-NMNM-LL4-300	A-CRF-NMNM-LL4-600	A-CRF-NMNM-LL4-900	A-CRF-RMNM-L1-300	A-CRF-RMNM-L1-600	A-CRF-RMNM-L1-900	A-CRF-RFRM-S1-060	A-CRF-QMAMNM-R2-50	A-CRF-RFQMAM-R2-50
	CFD200 cable, N-type (male) to RP SMA (male), 3 m	CFD400 cable, N-type (male) to N-type (male), 3 m	LMR-400 Lite cable, N-type (male) to N-type (male), 3 m	LMR-400 LITE cable, N-type (male) to N-type (male), 6 m	LMR-400 LITE cable, N-type (male) to N-type (male), 9 m	LMR-195 Lite cable, N-type (male) to RP SMA (male), 3 m	LMR-195 Lite cable, N-type (male) to RP SMA (male), 6 m	LMR-195 Lite cable, N-type (male) to RP SMA (male), 9 m	S141 cable, RP-SMA (male) to RP-SMA (female), 0.6 m	RG316 cable, QMA (male) to N-type (male)	RG316 cable, QMA (male) to RP-SMA (female)
Cable Type	CFD200	CFD400	LMR-400Lite	LMR-400 Lite	LMR-400 Lite	LMR-195 Lite	LMR-195 Lite	LMR-195 Lite	S141	RG316	RG316
Connector Type	N-type male to RP SMA male	N-type male to N-type male	N-type male to N-type male	N-type male to N-type male	N-type male to N-type male	N-type male to RP SMA male	N-type male to RP SMA male	N-type male to RP SMA male	RP-SMA male to RP-SMA female	QMA male to N-type male	QMA male to RP-SMA female
Cable Length	3 m	3 m	3 m	6 m	9 m	3 m	6 m	9 m	0.6 m	0.5 m	0.5 m
Outer Dimension	5 mm	10.3 mm	10.29 mm	10.29 mm	10.29 mm	4.95 mm	4.95 mm	4.95 mm	5 mm	2.54 mm	2.54 mm
Min. Bend Radius	12.7 mm	24.5 mm	25.4 mm	25.4 mm	25.4 mm	12.7 mm	12.7 mm	12.7 mm	12.7 mm	15 mm	15 mm
	55.4@2.5 GHz 86.5@5.8 GHz	22.2@2.5 GHz 35.5@5.8 GHz		22.2@2.5 GHz 35.5@5.8 GHz	22.2@2.5 GHz 35.5@5.8 GHz	62.4@2.5 GHz 98.1@5.8 GHz	62.4@2.5 GHz 98.1@5.8 GHz	62.4@2.5 GHz 98.1@5.8 GHz	75.4@3 GHz 98.4@5 GHz	206@2.4 GHz 345@6 GHz	206@2.4 GHz 345@6 GHz
Related Products	AWK-	AWK-4121, AWK-4131, AWK-6222, AWK-6232-M12				AWK-1121/1127, AWK-3121, AWK-3121-SSC, AWK-3131, AWK-5222, AWK-5232				AWK-3121-M12, AWK-3131-M12, AWK-5222-M12, AWK-5232-M12	

Termination Resistors



	A-TRM-50-NM	A-TRM-50-RM
Description	Termination resistor, 50 ohms, N-type (male)	Termination resistor, 50 ohms, RP-SMA (male)
Related Products	AWK-4121, AWK-4131, AWK-6222, AWK-6232	AWK-1121/1127, AWK-3121, AWK-3121-SSC, AWK-3131, AWK-5222, AWK-5232

Power Amplifiers



	A-WPA-2410gM-IDU	A-WPA-5410aM-IDU
Description	Wireless power amplifier	Wireless power amplifier
Signal Type	2.4 GHz band antenna (included)	5 GHz band antenna (included)
Connector Type	RP-SMA connector	RP-SMA connector
Power Output	1 W	1 W
Power Consumption	12 VDC	12 VDC
Power Cable	Power plug to power jack cable (included)	Power plug to power jack cable (included)
Dimensions	92 x 60 x 31 mm	92 x 60 x 31 mm
Related Accessories	<ul style="list-style-type: none"> N-type male to RP-SMA male cable RP-SMA male to RP-SMA female cable 	<ul style="list-style-type: none"> N-type male to RP-SMA male cable RP-SMA male to RP-SMA female cable
Related Products	AWK-1121/1127, AWK-3121, AWK-3121-SSC, AWK-3131, AWK-5222, AWK-5232	AWK-1121/1127, AWK-3121, AWK-3121-SSC, AWK-3131, AWK-5222, AWK-5232

Arrestors



	A-SA-NMNF-01
Frequency	0-6 GHz
Connector Type	N-type female to N-type male
Related Products	AWK-1121/1127, AWK-3121, AWK-3131, AWK-4121, AWK-4131, AWK-5222, AWK-6222

Adaptors



	A-ADP-RJ458P-DB9F-ABC01	A-ADP-QMAM-RF
Description	RJ45-to-DB9 adaptor for the ABC-01	QMA(male) to RP-SMA (female) adaptor for antenna
Related Products	All AWK series	AWK-3121-M12, AWK-3131-M12, AWK-5222-M12, AWK-5232-M12

Note: The actual product may vary in physical appearance, but the functionality will be the same.